

SÜDBAU

ARGENTINA

CENTRO DE SERVICIOS
REGIONAL

www.sudbau.com.ar



Pioneer Petrotech Services Inc.



Smart Gauges and Simple Software

www.pioneerps.com



Table of Contents

Company Profile	1
Features of PPS Electronic Gauges	2

MEMORY GAUGES

PPS25 Silicon-Sapphire Memory Gauge.....	4
PPS25XM Extreme Memory Gauge	5
PPS28 Quartz Memory Gauge	6
PPS28-200°C Quartz Memory Gauge	7
Memory Gauge Accessories.....	8

SPECIALIZED GAUGES

PPS51 Short Memory Gauge	10
PPS52 Slim 1/2"OD Memory Gauge	11
PPS53XM SPM Gauge.....	12
PPS55 Fast Sampling Memory Gauge.....	13
PPS56 Ultra-Fast Sampling Perforation Gauge	14
PPS61 RTD Temperature Gauge	15
PPS62XM Pressure & External RTD Memory Gauge	16

SRO AND MEMORY-SRO COMBO GAUGES

PPS26 Surface Read-Out Gauge.....	18
PPS58 Memory-SRO Combo Gauge	19
PPS63 RTD-CCL Memory-SRO Combo Gauge.....	20
PPS65 G-CCL Gauge.....	21

SURFACE MONITORING

PPS31 Wellhead Pressure Logger	23
PPS31M Multi-Channel Wellhead Pressure Logger.....	24
PPS33LR Long Range Wireless RemoteWatcher System.....	25



Table of Contents

PERMANENT GAUGES

PPS27 Permanent Downhole Monitoring System	29
PPS27 PDMS Surface Units.....	32
PPS27 PDMS Accessories	33
SmartGate Data Monitoring System	35

ARTIFICIAL LIFT MONITORING SYSTEMS

PPS53XM Side Pocket Mandrel Gauge	37
PCPLink Pump Monitoring & Control System.....	38

GEO THERMAL TOOLS

PPS71 PT Geothermal Tools	42
PPS71 PTS & PTS-C Geothermal Tools	44
PPS71 Elite & Quartz Geothermal Tools	46
PPS71 Gamma-CCL Geothermal Tools	48
Fullbore Spinner	50
PPS36 DepthWatcher.....	51

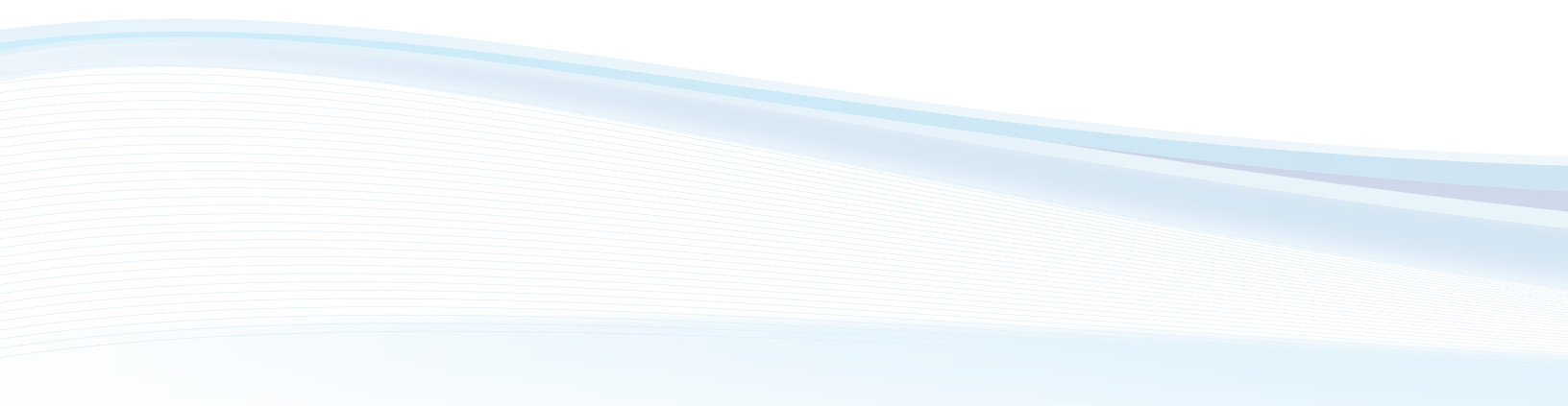

Company Profile

Pioneer Petrotech Services is headquartered in the beautiful city of Calgary, Alberta, Canada. PPS has regional offices, as well as multiple international representatives. The company was first incorporated in 1999 as a manufacturer of downhole pressure and temperature measurement gauges. From this point forward PPS has become recognized as a global leader in research, development, and manufacturing of high quality downhole pressure and temperature gauges, surface data loggers, permanent downhole gauges, and geothermal logging tools.



Investing in Technology

PPS's lab and calibration facilities have always been world class, and as part of PPS's commitment to innovation and quality, an Electron Beam Welding Machine has been acquired. EB Welding is one of the best controlled, most robust welding processes which produces the highest quality welds. The better welds translates to more reliable and robust downhole tools.

EB Welding Machine



Quality Control

Recognizing the need for a comprehensive Quality Management System as part of all operations, PPS has established a program with detailed quality control procedures.

“We strive to continually improve the effectiveness of our quality management system and our commitment to customer satisfaction by monitoring our performance against our established objectives and through leadership that promotes employee involvement.”

Features of PPS Electronic Gauges

Robust under high temperature and extreme well conditions

Based on state-of-the-art technologies and production engineering, PPS products can work consistently for long periods of time under sour or corrosive conditions, high working temperatures of up to 350°C and high pressure environments. The innovative mechanical and electronic design also makes the gauges resistant to vibration and interference.

Easy to operate with simple-to-use software

PPS's proprietary software programs are user friendly, with intuitive interfaces that make interactions with the tool and data, seamless. PPS memory gauges contain large memory capacities so there is no need to reprogram the gauges after every run, unless you are using a different sample rate. All data files are in ASCII format.

Low power consumption and long battery life

PPS gauges will work continuously over a long period of time consuming very little battery power. One single C size Lithium battery pack will power some models for over one year at a 30 second sampling rate.

High sensitivity and accuracy

Piezo or quartz crystal transducers provide high sensitivity for accurate data acquisition.



Memory Gauges



PPS25 Silicon-Sapphire Memory Gauge

The **PPS25 Silicon-Sapphire Memory Gauge** measures bottom hole pressures and temperatures helping to evaluate productivity during many phases of well development including drilling, evaluation and production. One of the key advantages of the PPS25 is how easy it is to use from start to finish including programming, running a job and gauge maintenance. The SmartView software has a very user friendly interface, so operators can feel confident running the gauges and retrieving data. Also once the gauge is programmed with the desired sampling rates and durations, jobs can be run consecutively without needing to reprogram the gauge, saving time on site.



Sensor Type	Silicon-Sapphire
--------------------	------------------

Pressure

Range-psi	6K 10K 15K
Accuracy-psi	± 0.03% FS
Resolution-psi	0.0003% FS
Drift-psi/year	<3

Temperature

Rating-°C	125 (257 °F) 150 (302 °F) 177 (350 °F)
Accuracy-°C	± 0.5
Resolution-°C	0.01

Characteristics

Service	Sour Services
Power Source	Lithium Battery Pack
Communication	USB / RS232
Data Set	Time / Pressure / Temperature
Max OD-inches	0.75 (19 mm) 1.25 (32 mm)
Overall Length-inches	9.8 (248 mm) 10.8 (274 mm)
Housing Material	Inconel 718 Stainless Steel 17-4
Sampling Rate	1 sec to 18 hours per sample
Memory Capacity	2,000,000 data sets (4 million data sets optional)

Applications:

- Pressure Build-up Tests
- Production Tests
- Pressure Gradients
- Pre/During/Post Stimulation Evaluation
- Interference Tests
- Fracturing Monitoring
- Injection Pressure Monitoring
- Coil Tubing Well Stimulation

PPS25XM Extreme Memory Gauge

The **PPS25XM Extreme Memory Gauge** features an advanced piezo pressure transducer, high temperature electronics technology and a welded housing in order to maximize the gauge's performance in high pressure and high temperature well conditions. Whether the gauge is used in high concentration CO₂ or H₂S the reinforced metal to metal seals prevent leaks, creating long term stability and reliability even in corrosive environments.



Applications:

- Pressure Build-up Tests
- Pressure Gradients
- Pre/During/Post Stimulation Evaluation
- Interference Tests
- Fracturing Monitoring
- Drill Stem Tests

Sensor Type

Advanced SOI

Pressure

Range-psi	10K 15K 20K 25K 30K
Accuracy-psi	± 0.03% FS
Resolution-psi	0.0003% FS
Drift-psi/year	<3

Temperature

Rating-°C	150 (302 °F) 177 (350 °F)
Accuracy-°C	± 0.5
Resolution-°C	0.01

Characteristics

Service	Sour Services
Power Source	Lithium Battery Pack
Communication	USB / RS232
Data Set	Time / Pressure / Temperature
Max OD-inches	0.75 (19 mm) 1.27 (32 mm) 1.375 (35 mm)
Overall Length-inches	17.8 (452 mm) 20 (508 mm)
Housing Material	Inconel 718 MP35N
Sampling Rate	1 sec to 18 hours per sample
Memory Capacity	2,000,000 data sets (4 million data sets optional)

PPS28 Quartz Memory Gauge

The **PPS28 Quartz Memory Gauge** has an integrated quartz pressure transducer and high temperature electronics making it highly accurate and stable, perfect for critical well testing. It is designed for applications where high quality data is required from a high temperature environment. The SmartView software which accompanies the gauge has a user friendly interface, so operators can feel confident programming the gauges and retrieving data.



Sensor Type	Quartz
--------------------	--------

Pressure

Range-psi	10K 16K 20K 25K
Accuracy-psi	± 0.02%
Resolution-psi	<0.01
Drift-psi/year	<0.02% FS

Temperature

Rating-°C	150 (302 °F) 177 (350 °F)
Accuracy-°C	± 0.2
Resolution-°C	<0.005

Characteristics

Service	Sour Services
Power Source	Lithium Battery Pack
Communication	USB / RS232
Data Set	Time / Pressure / Temperature
Max OD-inches	0.75 (19 mm) 1.27 (32 mm) 1.375 (35 mm)
Overall Length-inches	24.8 (629 mm) 25.2 (640 mm)
Housing Material	Inconel 718 MP35N
Sampling Rate	1s – 18hrs/per sample (0.1s – 1.8hrs/per sample optional)
Memory Capacity	2,000,000 data sets (4 million data sets optional)

Applications:

- Pressure Build-up Tests
- Pressure Gradients
- Interference Tests
- Injection Pressure Monitoring
- Drill Stem Tests
- Production Tests
- Pre/During/Post Stimulation Evaluation
- Fracturing Monitoring

PPS28-200°C Quartz Memory Gauge

The **PPS28-200°C Quartz Memory Gauge** integrates a hybrid quartz pressure transducer with PPS's proprietary hybrid high temperature electronics module, metal-to-metal and elastomer sealing technology for reliability in extreme conditions. Thanks to the latest innovations in hybrid electronic technology gauge life is greatly extended at extreme temperature, an advantage that allows the PPS28 gauge to dependably perform at a maximum temperature of 200 °C (392 °F).



Applications:

- **Pressure Build-up Tests**
- **Pressure Gradients**
- **Interference Tests**
- **Injection Pressure Monitoring**
- **Drill Stem Tests**
- **Production Tests**
- **Pre/During/Post Stimulation Evaluation**
- **Fracturing Monitoring**

Sensor Type

Quartz

Pressure

Range-psi	16K 20K 25K 30K
Accuracy-psi	± 0.02%
Resolution-psi	<0.01
Drift-psi/year	<0.02% FS

Temperature

Rating-°C	200 (392 °F)
Accuracy-°C	± 0.2
Resolution-°C	<0.005

Characteristics

Service	Sour Services
Power Source	Lithium Battery Pack
Communication	USB / RS232
Data Set	Time / Pressure / Temperature
Max OD-inches	0.75 (19 mm) 1.27 (32 mm) 1.375 (34 mm)
Overall Length-inches	24.8 (630 mm) 25.2 (640 mm)
Housing Material	Inconel 718 MP35N
Sampling Rate	1s – 18hrs/per sample (0.1s – 1.8hrs/per sample optional)
Memory Capacity	2,000,000 data sets

Memory Gauge Accessories



High Temperature Batteries



USB Gauge Interface Cable



Battery Tester



SmartView Software



Gauge Carrier



O-ring Grease



Carrying Case



O-rings



Crossovers

Specialized Gauges



PPS51 Short Memory Gauge

The **PPS51 Short Memory Gauge** is designed for applications with length limitations. The most common usage is for building this gauge into other downhole tools, such as water injection and plunger lift equipment. It is also used for general pressure surveys for gradient or build up tests. The gauge length is only 4.8 inches, including one half AA lithium battery pack. The user-friendly SmartView software is used for programming, downloading and processing data.

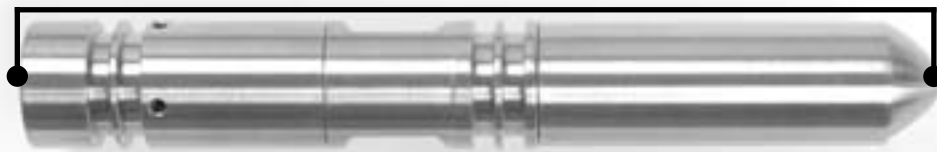

Actual length
4.8"

Sensor Type	Silicon Sapphire
-------------	------------------

Pressure

Range-psi	Up to 15 kpsi
Accuracy-psi	± 0.03% FS
Resolution-psi	0.0003% FS
Drift-psi/year	<3

Temperature

Rating-°C	150 (302 °F)
Accuracy-°C	± 0.5
Resolution-°C	0.01

Characteristics

Service	Sour Services
Power Source	Lithium Battery Pack
Communication	USB / RS232
Data Set	Time / Pressure / Temperature
Max OD-inches	0.75 (19 mm)
Overall Length-inches	4.8 (122 mm)
Housing Material	Inconel 718 Stainless Steel 17-4
Sampling Rate	1 sec. to 18 hours per sample
Memory Capacity	1,000,000 data sets

Applications:

- Stimulation Monitoring
- Pipeline Monitoring
- Fracture Monitoring
- Injection Pressure Monitoring
- Perforation Monitoring

PPS52 Slim 1/2" OD Memory Gauge

The **PPS52 Slim 1/2" OD Memory Gauge** is designed for applications with outside diameter challenges. The half inch outside diameter of this memory gauge allows users to run this tool in tight space conditions. The most common usage is for pressure and temperature measurement with small inner diameter coiled tubing.



Applications:

- Coiled Tubing Operations
- Drill Stem Tests
- Gradient Survey
- Pressure Build Up
- Stimulation Monitoring

Sensor Type

Silicon Sapphire

Pressure

Range-psi	Up to 10 kpsi
Accuracy-psi	± 0.03% FS
Resolution-psi	0.0003% FS
Drift-psi/year	<3

Temperature

Rating-°C	150 (302 °F)
Accuracy-°C	± 0.5
Resolution-°C	0.01

Characteristics

Service	Sour Services
Power Source	Lithium Battery Pack
Communication	USB / RS232
Data Set	Time / Pressure / Temperature
Max OD-inches	0.50 (12 mm)
Overall Length-inches	8.75 (222 mm)
Housing Material	Inconel 718 Stainless Steel 17-4
Sampling Rate	1 sec. to 18 hours per sample
Memory Capacity	1,000,000 data sets

PPS53XM Side Pocket Mandrel Memory Gauge

The PPS53XM Side Pocket Mandrel Memory Gauge (SPMG) has a welded housing and uses an advanced piezo pressure transducer to increase the gauges performance at high pressure. The tool is powered by two AA lithium battery packs for longer duration downhole. The gauge gets set within the mandrel using standard slickline procedures, and can be retrieved using standard side pocket mandrel tools. These gauges use the simple and powerful PPS SmartView software for all programming and data retrieval, whether done in the field or in the office.



Sensor Type	SOI
-------------	-----

Pressure

Range-psi	Up to 15 kpsi
Accuracy-psi	± 0.03% FS
Resolution-psi	0.0003% FS
Drift-psi/year	<3
Pressure reading	Tubing or Annulus

Temperature

Rating-°C	150 (302°F) 177 (351°F)
Accuracy-°C	± 0.5
Resolution-°C	0.01

Characteristics

Service	Sour Services
Power Source	Lithium Battery Pack
Communication	USB / RS232
Data Set	Time / Pressure / Temperature
Max OD-inches	1.0 (24.5 mm)
Overall Length-inches	12 (300 mm)
Housing Material	Inconel 718
Sampling Rate	1 sec. to 18 hours per sample
Memory Capacity	2,000,000 data sets

Applications:

- Gas lift optimization and memory gauge application
- Tubing pressure
- Frac monitoring
- Monitoring of flowing wells with no tubing restrictions
- Able to read tubing or annulus pressure depending on the model chosen

PPS55 Fast Sampling Gauge

The **PPS55 Fast Sampling Gauge** offers a great opportunity to catch sharp pressure changes, such as the pressure breaking point for reservoir fracturing or perforating operations. The gauge can record up to 500 data points per second. The large memory capacity of four million data points, allows operators to have sufficient downhole running time during job operations.



Sensor Type	Silicon Sapphire
Pressure	
Range-psi	Up to 15 kpsi
Accuracy-psi	± 0.1%
Resolution-psi	0.01
Drift-psi/year	<3
Temperature	
Rating-°C	150 (302 °F) 177 (351 °F)
Accuracy-°C	± 0.5
Resolution-°C	0.05

Characteristics

Service	Sour Services
Power Source	Lithium Battery Pack
Communication	USB / RS232
Data Set	Time / Pressure / Temperature
Max OD-inches	0.75 (19 mm) 1.25 (31 mm)
Overall Length-inches	9 (228 mm) 12 (304 mm)
Housing Material	Inconel 718 Stainless Steel 17-4
Sampling Rate	Up to 500 data sets per second
Memory Capacity	4,000,000 data sets

Applications:

- Stimulation Monitoring
- Injection Pressure Monitoring
- Perforation Monitoring

PPS56 Ultra-Fast Sampling Perforation Gauge

**115,200
 Samples
 per /Sec**



Applications:

- Perforation Monitoring
- Stimulation Monitoring
- Injection Pressure Monitoring

Sensor Type	Piezo
-------------	-------

Pressure	
Range-psi	Up to 30 kpsi
Accuracy-psi	± 0.03% FS
Resolution-psi	0.0003% FS
Drift-psi/year	<3

Temperature	
Rating-°C	150 (302 °F)
Accuracy-°C	± 0.5
Resolution-°C	0.01

Characteristics	
Service	Sour Services
Power Source	Lithium Battery Pack
Communication	USB / RS232
Data Set	Time / Pressure / Temperature
Max OD-inches	1.27 (32 mm)
Overall Length-inches	18.625 (473 mm)
Housing Material	Inconel 718
Fast Sampling Burst Rate	1,800 samples/sec to 115,200 samples/sec
Regular Sampling Rate	1 sec to 18 hrs per sample
Memory Capacity	2,000,000 data sets
Carrier Sizes-inches	1.65 / 2.0 / 2.5

The **PPS56 Ultra-Fast Sampling Perforation Gauge** utilizes PPS’s robust electronic design with silicon on insulator technology to capture fast sampling burst rates from 7,200 to 115,200 samples per second. This fast sampling gauge has a large two million data set memory which gives the user the capability to set and capture critical events in two ways:

- **Pressure Level** – Fast sampling triggered at a desired pressure level point
- **Window Level** – Fast sampling triggered at a desired pressure amount over a set time period

The PerfView software was designed specifically for the perforation gauge and can be used for all programming and data retrieval. The PPS56 gauge makes a perfect tool for various applications requiring fast and accurate burst sampling up to 30kpsi.

Gauge & carrier shown above.

PPS61 RTD Temperature Gauge

The **PPS61 RTD Temperature** gauge is for applications that require a fast response to temperature changes. It allows analysts to quickly diagnose downhole problems such as tubing or casing leakage. It can also be used for monitoring stimulation operations to see which zones are more effective. Using the same highly integrated design principles, the tool can be operated in areas with limited space.



Sensor Type	RTD
Pressure	
Range-psi	Up to 20 kpsi
Temperature	
Rating-°C	150 (302°F) 177 (351°F)
Accuracy-°C	± 0.1
Resolution-°C	0.01

Characteristics

Service	Sour Services
Power Source	Lithium Battery Pack
Communication	USB/RS232
Data Set	Time/Temperature
Max OD-inches	0.75 (19 mm) 1.25 (31 mm)
Overall Length-inches	10 (254 mm)
Housing Material	Inconel 718/Stainless Steel 17-4
Sampling Rate	1 sec to 18 hours per sample
Memory Capacity	1,000,000 data sets, Larger memory is available

Applications:

- Temperature Logging
- Stimulation Monitoring
- Casing Leak Detection
- Tubing Leak Detection
- Injection Monitoring

PPS62XM Pressure & External RTD Gauge

The **PPS62XM Pressure & External RTD Gauge** combines a piezo sensor with a highly accurate resistance temperature detector (RTD) probe to allow users to obtain fast pressure and temperature responses. This product is primarily designed for detecting tubing and casing leakage problems. CCL can be added to the gauge for immediate measurement of temperature and pressure while locating casing collars. The gauge can be run in tandem with a depth measurement system, such as the PPS36 DepthWatcher which will enable the user to record line tension, speed and depth in conjunction with downhole data from the gauge.



Applications:

- Stimulation Monitoring
- Pressure Build-up Tests & Gradients
- Production Tests
- Tubing and Casing Leakage Checking
- Interference Tests
- Injection Pressure Monitoring
- Coil Tubing Operation
- Monitor Artificial Lift Valve Efficiency

Sensor Type	Peizo/RTD
Pressure	
Range-psi	10K 15K 20K
Accuracy-psi	± 0.03% FS
Resolution-psi	0.0003% FS
Drift-psi/year	<3
Temperature	
Rating-°C	150 (302°F) 177 (350°F)
Accuracy-°C	± 0.2
Resolution-°C	0.01
Characteristics	
Service	Sour Services
Power Source	Lithium Battery Pack
Communication	USB / RS232
Data Set	Time / Pressure / Temperature
Max OD-inches	1.27 (32 mm)
Overall Length-inches	22.3 (566 mm)
Housing Material	Inconel 718
Sampling Rate	1s – 18 hrs/per sample (0.1s – 1.8 hrs/per sample optional)
Memory Capacity	2,000,000 data sets

Surface Read Out and Memory-SRO Combo Gauges



PPS26 Surface Read-Out Gauge

The **PPS26 Surface Readout (SRO) Gauge** is designed for real time sampling of pressure and temperature data for applications focused on production optimization, well stimulation or reservoir development. Due to the gauge's stability and strong transmission distance, the PPS26 can send data from downhole to surface through one single conductor wireline cable at well depths up to 7,000 meters.



Sensor Type	Silicon-Sapphire	Quartz
Pressure		
Range-psi	Up to 20 kpsi	Up to 30 kpsi
Accuracy-psi	± 0.03% FS	± 0.02%
Resolution-psi	0.0003% FS	<0.01
Drift-psi/year	<5	± 0.02% FS

Temperature		
Rating-°C	150 (302 °F) 177 (350 °F)	177 (350 °F) 200 (392 °F)
Accuracy-°C	± 0.5	± 0.2
Resolution-°C	0.01	<0.005

Characteristics		
Service	Sour Services	Sour Services
Power Source	+12 VDC/100 mA	+12 VDC/100 mA
Communication	USB / RS232	USB / RS232
Data Set	Time / Pressure / Temperature	Time / Pressure / Temperature
Max OD-inches	1.44 (36 mm)	1.44 (36 mm)
Overall Length-inches	8.26 (209 mm)	17.64 (448 mm)
Housing Material	Inconel 718 SS17-4	Inconel 718
Sampling Rate	1 sec per sample	1.5 sec per sample

Applications:

- Pressure Build-up Tests
- Pressure Gradients
- Interference Tests
- Injection Pressure Monitoring
- Drill Stem Tests

PPS58 Memory-SRO Combo Gauge

The **PPS58 Combo SRO-Memory Gauge** offers flexibility in gauge operations for customers who want to use the gauge in either memory working mode or surface read out mode. An SRO adapter is installed on the gauge to connect to a wireline cable head to be able to change the gauge from a memory tool to a surface read out tool. SmartView software is used for memory gauge applications and a PPS26 surface unit with PPS SRO software is used for SRO operations.



Applications:

- **Pressure Build-up Tests**
- **Pressure Gradients**
- **Production Tests**
- **Interference Tests**
- **Injection Pressure Monitoring**
- **Drill Stem Tests**
- **Pre/During/Post Stimulation Evaluation**
- **Fracturing Monitoring**
- **Coil Tubing Well Stimulation**

Sensor Type	Piezo	Quartz
Pressure		
Range-psi	Up to 20 kpsi	Up to 20 kpsi
Accuracy-psi	± 0.03% FS	± 0.02% FS
Resolution-psi	0.0003% FS	<0.01
Drift-psi/year	< 3	< 0.02%FS
Temperature		
Rating-°C	150 (302 °F) 177 (350 °F)	150 (302 °F) 177 (350 °F)
Accuracy-°C	± 0.5	± 0.2
Resolution-°C	0.01	<0.005

Characteristics

	Sour Services	Sour Services
Service	Sour Services	Sour Services
Power Source	12 VDC Lithium Battery	25 VDC/30mA Lithium Battery
Communication	USB / RS232	USB / RS232
Data Set	Time / Pressure / Temperature	Time / Pressure / Temperature
Working Mode	Memory or SRO	Memory or SRO
Max OD-inches	1.44 (36 mm)	1.44 (36 mm)
Overall Length-inches	11.4 (290 mm)	30.4 (772 mm)
Housing Material	Inconel 718 SS 17-4	Inconel 718
Sampling Rate	1 sec to 18 hours per sample	1 sec to 18 hours per sample
Memory Capacity	2,000,000 data sets	2,000,000 data sets

PPS63 RTD-CCL Memory-SRO Combo Gauge

The **PPS63 RTD-CCL Memory-SRO Combo Gauge** with its highly accurate RTD probe measures immediate temperature gradients while also measuring pressure and locating casing collars by CCL (casing collar locator). The gauge can be run in tandem with a depth measurement system, such as the PPS36 DepthWatcher which will enable the user to record line tension, speed and depth in conjunction with downhole data from the gauge.

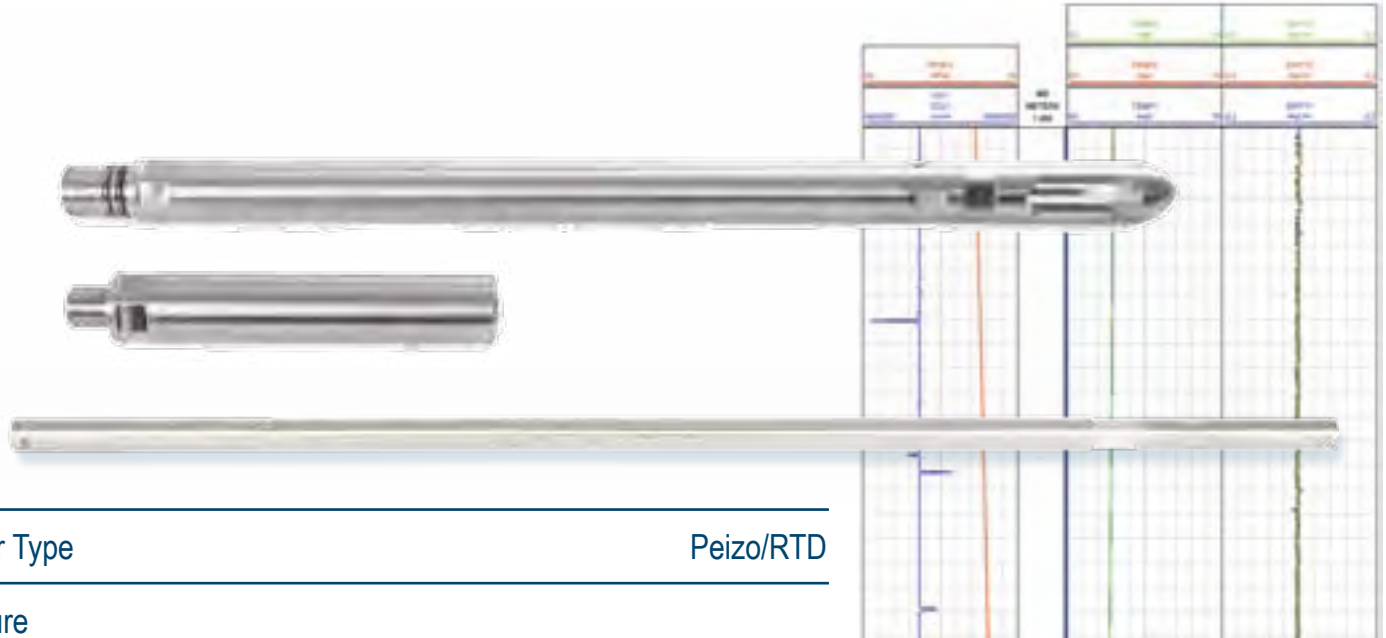

Sensor Type	Peizo/RTD
-------------	-----------

Pressure

Range-psi	Up to 15K
Accuracy-psi	± 0.03% FS
Resolution-psi	0.0003% FS
Drift-psi/year	<3

Temperature

Rating-°C	150 (302°F) 177 (350°F)
Accuracy-°C	± 0.5
Resolution-°C	0.01

Characteristics

Service	Sour Services
Power Source	2.7 - 3.9 VDC, Lithium Battery Pack
Communication	USB / RS232
Data Set	Time / Pressure / Temperature / RTD / CCL
Max OD-inches	1.5 (38 mm)
Overall Length-inches	33.5 (85 mm)
Housing Material	Inconel 718
Sampling Rate	0.1 second to 1.8 hours per sample
Memory Capacity	1,000,000 data sets

Applications:

- Locate casing or tubing damage such as corrosion holes or leaks
- Monitor the efficiency of artificial lift valve systems
- Record accurate static and flowing temperature readings
- Determine contribution and cross flow over multiple commingled intervals
- Production logging

PPS65 Gamma & CCL Memory/SRO Gauge

The **PPS65 Gamma & CCL Memory/SRO Gauge** is designed for high temperature downhole conditions. The tool measures casing collar location, and gamma rays, and can be configured as either a memory tool or surface read out tool (SRO) tool.

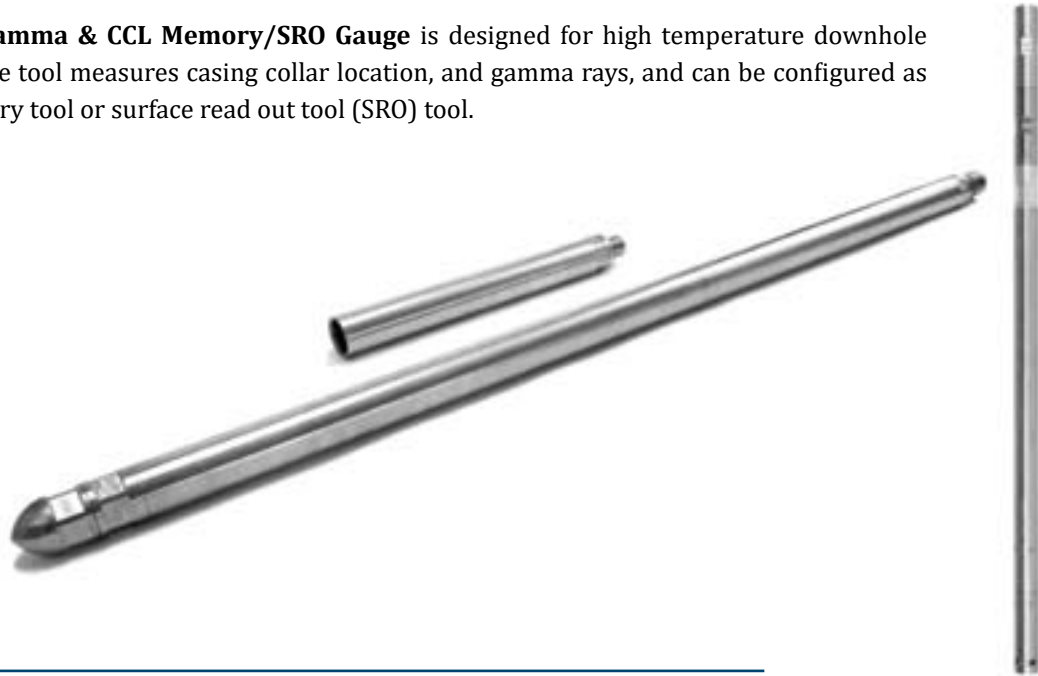

	Memory	SRO
--	--------	-----

Gamma Measurement

Sensor Type	Crystal, NaI (scintillation type)	Crystal, NaI (scintillation type)
Sensitivity	Typically 1.5 CPS/API	Typically 1.5 CPS/API

Characteristics

Pressure Rating—psi	20 kpsi	20 kpsi
Temperature Rating—°C	177 (350 °F)	177 (350 °F)
Service	Sour Services	Sour Services
Power Source	Lithium Battery	SRO Receiver / Warrior
Communication	USB / Serial	E-line
Data Set	Time / Gamma / CCL	Time / Gamma / CCL
Max OD—inches	1.5	1.5
Housing Material	Inconel 718	Inconel 718
Sampling Rate	10 samples per second	10 samples per second
Memory Capacity	1M or 2M data sets	1M or 2M data sets
Operation Voltage	7.2 VDC	60V
Connector	Lemo 4 pin with locker	Cable Head

Features:

- Operates in either memory or surface read out mode
- Surface read out mode using e-line is compatible with the Warrior or PPS SRO acquisition system
- Can be combined with PPS36 DepthWatcher if depth measurement is needed

Surface Monitoring



PPS31 Wellhead Pressure Logger



The **PPS31 Wellhead Pressure Logger** is a programmable gauge that samples pressure and temperature providing real time monitoring. The logger has a highly viewable LCD display where data can be read and also has built in memory. The intrinsically safe design means this logger can be used in hazardous areas.

Sensor Type Silicon-Sapphire

Pressure

Range-psi	Up to 15 kpsi
Accuracy-psi	± 0.03% FS
Resolution-psi	0.0003% FS
Drift-psi/year	<3

Temperature

Sensor Rating-°C	-20 (-4 °F) to 70 (158 °F)
Accuracy-°C	± 0.5
Resolution-°C	0.01
Environmental Temperature-°C	-40 (-40 °F) ~ 70 (158 °F)*

Applications:

- Gas Wellhead Build-up Tests
- Stimulation Monitoring
- Pipeline Monitoring
- Fracture Monitoring
- Wellhead Monitoring
- Injection Pressure Monitoring

Characteristics

Service	Sour Services (available upon request)
Power Source	Lithium Battery Pack
Data Set	Time / Pressure / Temperature
Data Receiving Mode	Wireless (915 MHz, ISM)
Wireless Transmission Distance	328' (100 m)
Overall Length-inches	10 (254 mm)
Work Mode	MRO / SRO
Sample Rate	1 sec to 18 hours per sample
Memory Capacity	2,000,000 data sets
Connection	1/2" NPT/Autoclave
Safety Rating	Class I, Division 1, Exia IIC T4, CE Marking (-40 °C~55 °C)

* LCD Display environmental temperature is -20 °C~ 70 °C, Wireless is Optional

PPS31M Multi-Channel Wellhead Pressure Logger

The PPS31M Multi-Channel Wellhead Pressure Logger is integrated with up to four channels, one internal (pressure) and three wired externally. The three external channels can be SOI pressure transducers, or RTD temperature probes, in the customer's preferred configuration. This is a good choice for applications where high data quality is required. The main unit and the other transmitters can be mounted onto the wellhead to measure readings such as: tubing, casing and vent pressures or temperatures. There is also the option to have a wireless radio transmitter and receiver with a transmission distance up to 100m line of sight.

Applications:

- Gas Wellhead Build-up Tests
- Stimulation Monitoring
- Pipeline Monitoring
- Fracture Monitoring
- Wellhead Monitoring
- Injection Pressure Monitoring
- Perforation Monitoring



Sensor Type

Piezo (or Quartz*) / RTD

Pressure

Range-psi	10K 15K 20K
Accuracy-psi*	± 0.03% FS
Resolution-psi*	0.0003% FS

Temperature

Sensor Type	RTD (Pt1000)
Range-°C	-30 (-22 °F) to 85 (185 °F)
Accuracy-°C	0.5
Resolution-°C	0.005

Characteristics

Channels	Up to 4
Display	Alphanumeric
Memory Capacity	20,000,000 samples
Sensor Channels	4 sensors; One built in, three external wired
External Wired Sensors	1.25" OD, ¼" HP Pressure sensors 15K/85C 1.25" OD, ½" NPT Temperature sensor range -30C to 85C
Adapter	¼" HP pin to ½" NPT pin adaptor, Inconel 718
Service	Sour Services
Power Source	Lithium Battery Pack
Data Set	Time / Pressure / Temperature / RTD
Work Mode	SRO / MRO
Sample Rate	1s-18hr/sample
Connection	½" NPT / Autoclave
Safety Rating	Class I Division 1 Group A, B, C and D, T4 Ex ia IIC T4
Operating Temperature-°C	-30 (-22 °F) to 60 (140 °F)
Operating Humidity	5 to 95% Non-Condensing

PPS33LR Long Range Wireless RemoteWatcher

PPS33LR RemoteWatcher is a low-power multi-sensor monitoring system designed for applications that require simultaneous multipoint pressure, differential pressure, temperature and/or flow monitoring. The system is highly adaptive and cost effective. Customers can choose from multiple sensor and surface unit configurations based on the number of sensors needed and the transmission distance required.

The **Gateway-sensor configuration** allows customers to use the PPS Gateway and up to 16 sensors as a network. The Gateway is capable of transferring data to a computer and other devices, through USB and RS232/485 communication. The Gateway also has a 2 GB (15,000,000 samples at 60 sec/sample) SD memory card as backup in the unlikely event of a power interruption.

The **Gateway System configuration** allows customers to use the PPS Gateway and up to 16 sensors as a network, with the key difference being the LCD display with keypad and 16 real time status indicators. This allows customer to easily monitor sensor readings from the display panel, as well as check each sensor's signal strength and battery remaining. The status indicators clearly show which sensors are online or offline. The system also allows for streaming of remote data via the internet.



PPS33LR RemoteWatcher

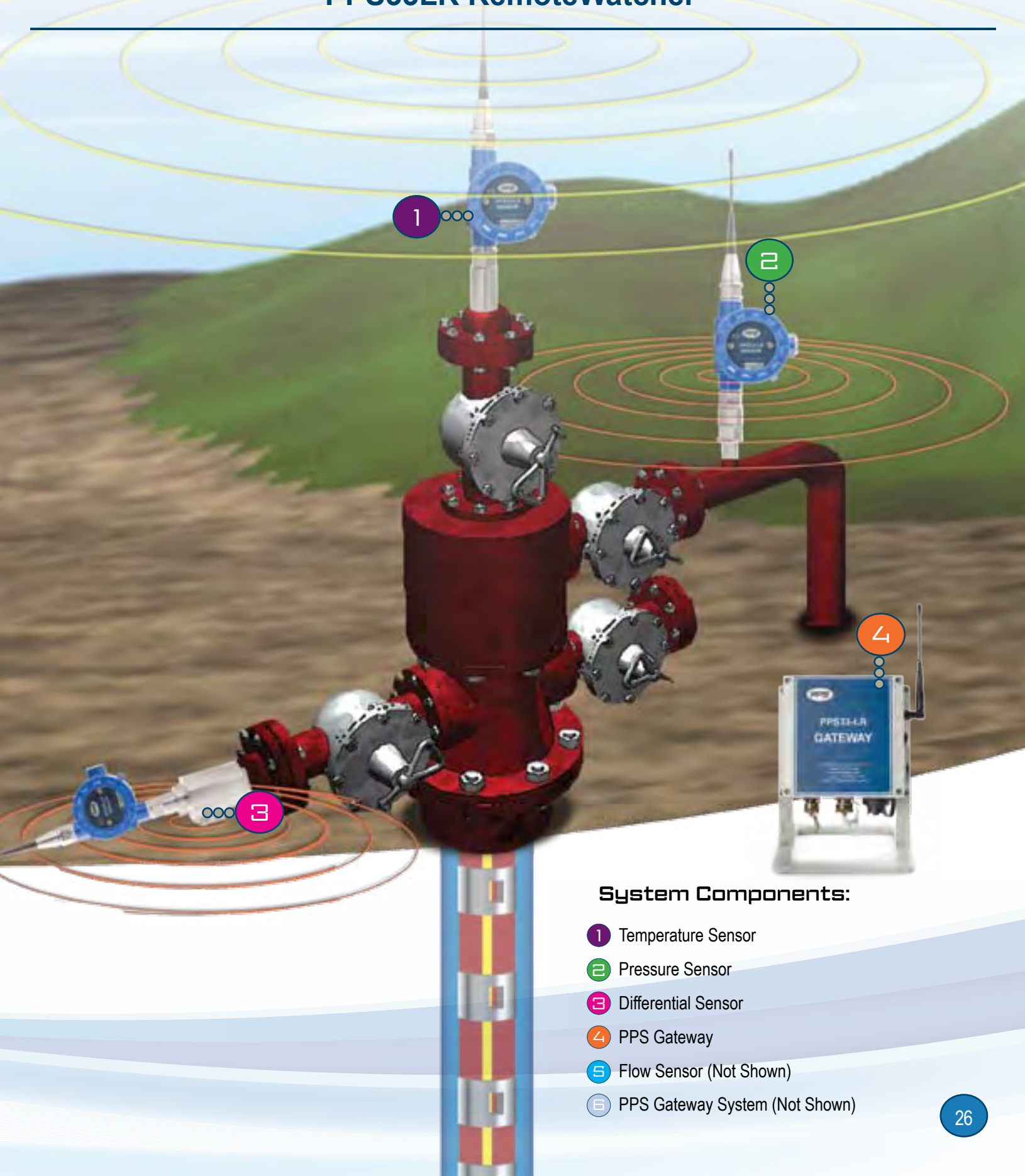

System Components:

- 1 Temperature Sensor
- 2 Pressure Sensor
- 3 Differential Sensor
- 4 PPS Gateway
- 5 Flow Sensor (Not Shown)
- 6 PPS Gateway System (Not Shown)

PPS33LR Long Range Wireless RemoteWatcher

PPS33LR Wireless Sensors

Sensor	Pressure (P+T) Sensor	Temperature Sensor	Turbine Flow Sensor **	Differential Pressure Sensor
Sensor Type	Silicon-Sapphire Quartz Optional	RTD	Turbine	Silicon-Sapphire
Range	5K 10K 15K 20K psi *	-50°C to 200°C	15-1500 pulse/sec	Line: 2.9kpsi; Diff: 290 psi
Service	Sour Services			
Environmental Temperature	-40 °C (-40 °F) to 70 °C (158 °F)			
Battery Type	Lithium Size D 3.6V			
Memory	4 million data sets			
Safety Rating	Ex ia IIB T4 Ga; IS CL I, DIV 1, GRP C and D T4 Class I, Zone 0, AEx ia IIB T4 Ga			
Connection	1/2" NPT (others by request)	1/2" NPT	1" NPT	1/8" NPT Female
Wireless Transmission Distance	up to 7 km Line of Sight, further w/high gain antenna			
Transmission Power	+24dBm (250mW) Software selectable			

PPS33LR Gateways

Type of Unit	Gateway	Gateway System
Environmental Temperature	-40°C to 70°C	-40°C to 70°C***
Power Source	DC 9-32 V	DC 9-32 V
Sample Rate	1 sec to 120 sec/sample	1 sec to 120 sec/sample
Dimension–inch	6.3 x 6.2 x 3.19	6.3 x 6.3 x 3.19
Data Set	Time/Pressure/ Temperature/Flow Rate	Time/Pressure/ Temperature/Flow Rate
Interface Types	USB/RS232/RS485	USB (RemoteView Software) RSRS232/RS485 (Modbus/Push) GSM - Cell Network
Wireless Transmission Distance	up to 7 km (unobstructed line of sight) or further with high gain antenna	7 km (unobstructed line of sight) or further with high gain antenna

* Other pressure ranges available upon request

** Transmitter limits only

*** LCD Display environmental temperature is -20 °C~ 70 °C

Permanent Gauges



PPS27 Permanent Downhole Monitoring Systems

Overview

PPS27 permanent downhole monitoring systems have multiple levels of gauges and surface data acquisition units (SDAU) to choose from. This equipment can be used for diverse applications from low pressure CBM wells to extremely corrosive wells with high concentration carbon dioxide [CO₂] and/or hydrogen sulfide [H₂S].

PPS can also provide all the accessories necessary for intelligent well completions. This includes gauge carriers, downhole cable, cable protectors, cable head and wellhead outlets.

Premium, Elite & LPLT Series

Customers can choose from single to multi-drop permanent gauge completions with an option of gauge reading tubing pressure or annulus pressure. All of PPS's state-of-the-art downhole tools incorporate industry leading sensors, innovative electronic components, and an electron beam welded housing design.

The Premium Series offers piezo silicon-sapphire downhole electrical gauges that record point measurements of pressure, temperature and/or vibration. They are rated up to 10,000 psi [68,947 kPa] and 125°C [257°F], however higher ratings are available by request.

Benefits:

- **Analyze draw-down and build-up pressure transients to enhance production**
- **Increase asset management by enabling a deeper understanding of reservoir performance and optimization**
- **Acquire pressure and temperature information without requiring well intervention**

The Elite Series offers highly accurate quartz downhole electrical gauges that record point measurements of pressure and temperature. They are rated up to 25,000 psi [172,369 kPa] and 200°C [392°F], and additional pressure and temperature ranges are available upon request.

The low pressure low temperature LPLT Series offers quartz downhole electrical gauges with the high accuracy and resolution associated with quartz gauges at a mid-range cost. They are rated up to 10,000 psi [68,947 kPa] and 130°C [266°F].

There are different SDAU configurations to choose from, including SmartWatcher Touch which provides instant data trending and charting or SmartWatcher II which makes it possible to connect up to four wells—with a maximum of four gauges per well—and therefore a total of 16 gauges communicating to the surface unit.

Analog Series

The **PPS27 Analog Series** is specifically designed for low cost permanent low pressure, low temperature monitoring and remediation monitoring. Using 4-20mA output and integrated cable head, this option can provide high quality data, with easy installation and no need for additional surface monitoring equipment. Overall the design is based on the Premium Series of piezo silicon-sapphire gauges, but modified to provide a reliable and effective alternative for applications below 3,000 psi and 110°C.



Elite Series Quartz Gauges

Sensor	Quartz
Pressure Ranges*–psi	10K 16K 25K
Temperature Range*–°C	150 177 204
Service	H ₂ S / CO ₂ Services

* Additional pressure and temperature ranges available upon request

Premium Series Piezo Gauges

Sensor	Piezo
Pressure Ranges*–psi	6K 10K
Temperature Range*–°C	20 to 125
Vibration Sensor	MEMS Accelerometer
Service	H ₂ S / CO ₂ Services upon request

* Additional pressure and temperature ranges available upon request

LPLT Series Quartz Gauges

Sensor	Quartz
Pressure Ranges–psi	5K 10K
Temperature Range–°C	20 to 130
Service	H ₂ S / CO ₂ Services upon request

Analog Series Silicon Sapphire Gauges

Sensor Type	Silicon-Sapphire
Pressure Range–psi	0 to 3K psi
Temperature Range–°C	20 to 110

System Applications

- Production optimization
- Injection monitoring
- CO₂ injection monitoring
- Observation well monitoring
- Pump system monitoring
- Well testing without additional equipment
- Intelligent completions
- Pressure build-up surveys without additional equipment

PPS27 PDMS Diagram

System Components:

- 1 Surface Data Acquisition Unit
- 2 Wellhead Outlet
- 3 Cable Protectors
- 4 Electric Downhole Cable
- 5 Gauge Carrier
- 6 Downhole Gauges

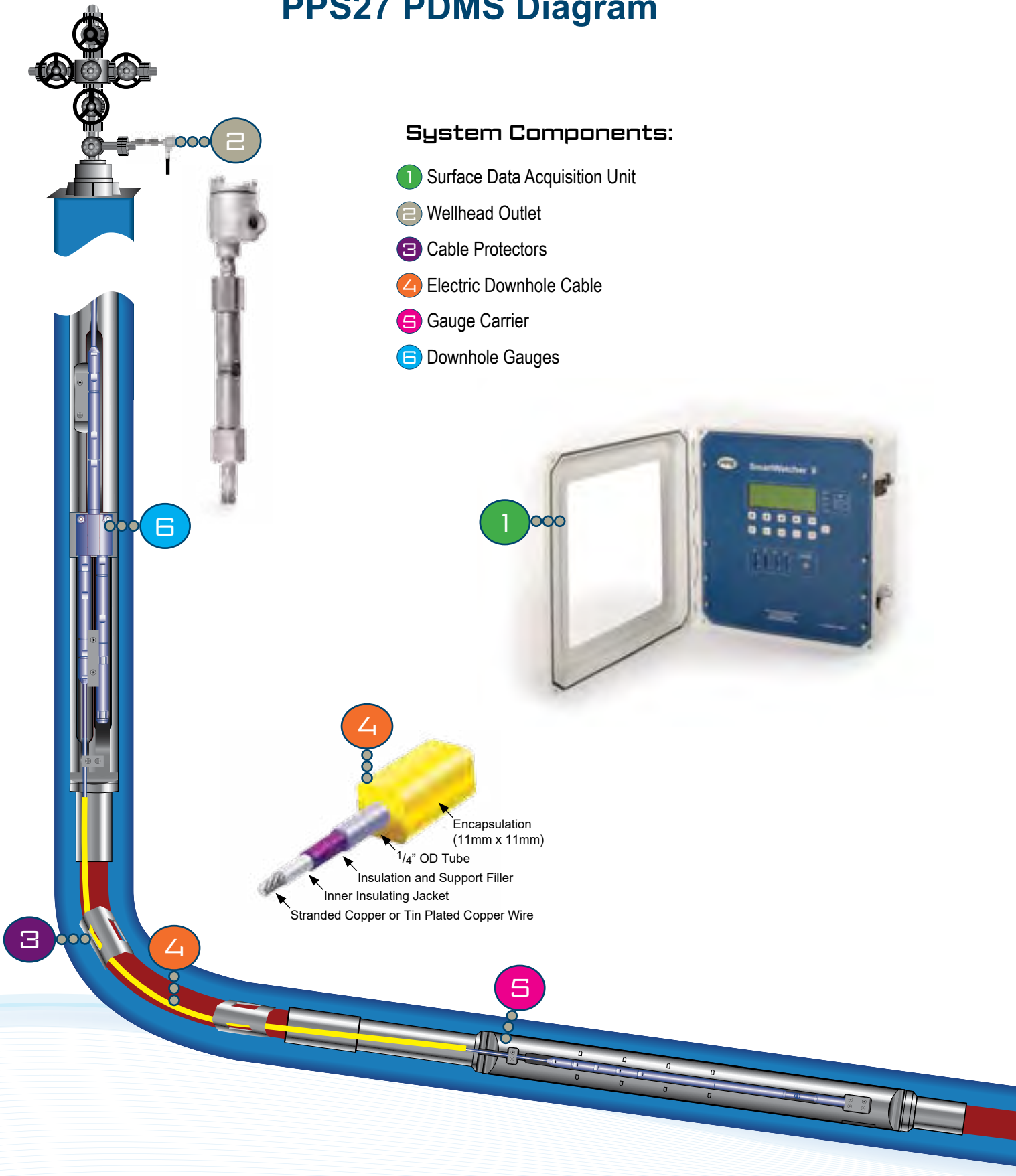

PPS27 PDMS Surface Units

SmartWatcher

PPS SmartWatcher is a data acquisition unit available in multiple configurations for downhole data interfacing, processing and logging. This system has a modular structure that connects to multiple gauges with a single cable (maximum four downhole gauges) and supports Modbus/RTU communication. The modular structure allows for maximum flexibility with unit expansion for different applications, enhanced reliability in harsh environments, independent mobility for unit improvement, upgrades and certification, and convenience for production and unit maintenance.

SmartWatcher II

This is the most advanced SDAU that PPS offers, because it is able to have up to four wells communicating to it. Each well can have a maximum of four gauges connected for a total of 16 gauges communicating with the SmartWatcher II unit. Other features include internal memory, an SD card, Modbus/Push data port

via RS485 or RS232, AC & DC power entries, and solar station availability. The electronics are enclosed in a NEMA-4 box with a large viewing window so that data reading and system status can be monitored without opening the door. The unit is compatible with PPS's online remote monitoring.

SmartWatcher Touch

SmartWatcher Touch surface data acquisition unit provides a convenient touch screen for viewing real time numeric data or graphical representations of the data. Two channels of pressure, one channel of temperature and three axes of vibration can all be displayed at the same time. The samples that are displayed are simultaneously saved to text files which can later be extracted to a standard USB memory drive.



PPS27 PDMS Accessories

Gauge Carrier

PPS gauge carriers are designed for long term reliability with pressure testable metal to metal seals and can be configured for single, dual and Y-splice gauges. Materials are available to meet any type of downhole environment, such as 4140, 4150, 13CrL80, SN95, 1925 or Super 13 Chrome. The carrier is machined from one solid block of material and complies with API 5CT guidelines.

Permanent Downhole Cable

The standard cable that PPS uses is suitable for high pressure, high temperature environments. The cable has ¼-inch outside diameter steel outer cable and can be either SS316 or Alloy825. Other features of this cable include:

- Maximum pressure up to 20,000 PSI
- Temperature rating up to 150°C or 200°C based on material and environment
- Tensile rating >1 tonne typical
- Conductor 18AWG stranded wire

Cable Head & Cable Splice

The cable head and cable splice have multiple metal to metal seals and are pressure testable in the field. The cable head has rotation and vibration protection built in. The specifications are:

- ¼" Tube cable with max OD 0.875"
- SS316 / Inconel718
- Pressure Rating 25,000 PSI
- Temperature Rating 0 to 200 °C



PPS27 PDMS Accessories

Cable Protectors

Cable protectors are used across the tubing joints to protect the cable from mechanical damage. Customers can choose from iron cast or cannon style protectors. Iron cast protectors are recommended due to their exceptional longitudinal and rotational slippage resistance (Longitudinal > 5 tonnes, Rotational > 3 tonnes), and crush resistance (~4 tonnes).

Wellhead Outlet

The wellhead outlet is a device that is used to connect downhole cable to the surface data acquisition system. Its primary purpose is to provide wellhead pressure control upon cable termination. It has metal to metal seals, accepts one conductor and can accommodate most flanged connections.

PPS Software

SmartWatcher software allows for system configuration and diagnostics. It has full Modbus support and displays data in real time as needed. Data can also be downloaded from an SD card and flash memory.



SmartGate Data Monitoring System

In applications where it is critical to have access to real time data, SmartGate provides a convenient solution. At the job site a surface unit is setup to communicate via a wireless internet gateway. Then customers can use SmartGate’s web-based platform, to access and download real time data as needed. Data from the tools is also stored in the SDAU’s or logger’s memory and on secured servers at the PPS headquarters in Calgary, designated solely for PPS clients.

The SmartGate system is capable of sending alert e-mail and text messages to registered users, if the data received from the tools moves outside of the acceptable parameters created on setup. Users can also change the alarm settings and sampling rates of the connected device, if changes need to be made to ensure optimum operations. This gives client’s peace of mind knowing their job site is being monitored day and night.



Artificial Lift Monitoring Systems



PPS53XM Side Pocket Mandrel Memory Gauge

The PPS53XM Side Pocket Mandrel Memory Gauge (SPMG) has a welded housing and uses an advanced piezo pressure transducer to increase the gauges performance at high pressure. The tool is powered by 2 AA lithium battery packs for longer duration downhole. The gauge gets set within the mandrel using standard slickline procedures, and can be retrieved using standard side pocket mandrel tools. These gauges use the simple and powerful PPS SmartView software for all programming and data retrieval, whether done in the field or in the office.



Sensor Type	SOI
-------------	-----

Pressure

Range-psi	Up to 15 kpsi
Accuracy-psi	± 0.03% FS
Resolution-psi	0.0003% FS
Drift-psi/year	<3
Pressure reading	Tubing or Annulus

Temperature

Rating-°C	150 (302°F) 177 (351°F)
Accuracy-°C	± 0.5
Resolution-°C	0.01

Characteristics

Service	Sour Services
Power Source	Lithium Battery Pack
Communication	USB / RS232
Data Set	Time / Pressure / Temperature
Max OD-inches	1.0 (24.5 mm)
Overall Length-inches	12 (300 mm)
Housing Material	Inconel 718
Sampling Rate	1 sec. to 18 hours per sample
Memory Capacity	2,000,000 data sets

Applications:

- Gas Lift Optimization and Memory Gauge Application
- Tubing pressure
- Frac monitoring
- Monitoring of flowing wells with no tubing restrictions
- Reads tubing or annulus pressure depending on the model chosen

PCPLink Monitoring & Control System

The **PCPLink (progressive cavity pump)** monitoring system provides real time downhole pressure measurements and the full vibration spectrum of three axes creating a snapshot of whether PCP is operating within optimum parameters. The SmartWatcher Touch surface unit was specifically designed to provide a convenient interface for viewing real time numeric data or graphical representations of the data.

By using vibration as a leading indicator of equipment health, operators can recognize issues and plan

preventative maintenance thereby protecting and increasing pump longevity. As well pressure data can prompt operators to vary the pump speed, maximizing pump efficiency and production, all while maintaining bottom-hole pressure.

Having the ability to control the pump is essential to maintaining optimum pump lifting efficiency. Using PCPLink operators can monitor pressure, and temperature. Using these values, alarms can be setup for monitoring and control of the pump.



System Applications

- **Dual pressure monitoring provides information on PCP operating conditions**
- **Diagnose and plan PCP maintenance to prevent system failure and reduce pump down time.**
- **Increase pump lifting efficiency while controlling the pump operating time**

PCPLink Monitoring & Control System

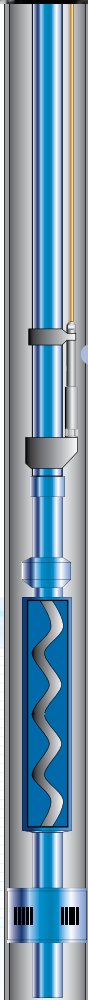

PCPLink Dual Pressure Gauge

Pressure

Pressure Sensor	Dual Piezo
Pressure Range-psi	10K
Accuracy-full scale	± 0.03% FS
Resolution-psi @ 1 sec	0.02

Temperature

Temperature Range-°C	20 to 177
Accuracy-°C	± 0.5
Resolution-°C @ 1 sec	0.01

Vibration

Vibration Sensor	MEMS Accelerometer
Measurement Range	± 12g ± 50g
Resolution	2.9 mg

Other Characteristics

Service	H ₂ S/CO ₂ Services upon request
Maximum OD-inches	1.0
Data Set	Time / Pressure 1 & 2 / Temperature / Vibration
Housing Material	Inconel 718

Geothermal Tools



Choose a PPS71 Geothermal Tool

	Memory Mode	SRO Mode	Temperature Max.	Pressure Max.	Flow Profile	Casing Collar Locator	Gamma Ray	Memory Capacity
PPS71 PT	<input checked="" type="checkbox"/>	<input checked="" type="checkbox"/>	350°C	10kpsi				6,000,000
PPS71 PTS	<input checked="" type="checkbox"/>	<input checked="" type="checkbox"/>	350°C	10kpsi	<input checked="" type="checkbox"/>			6,000,000
PPS71 PTS-C	<input checked="" type="checkbox"/>	<input checked="" type="checkbox"/>	350°C	10kpsi	<input checked="" type="checkbox"/>	<input checked="" type="checkbox"/>		2,000,000
PPS71 Elite	<input checked="" type="checkbox"/>	<input checked="" type="checkbox"/>	350°C	10kpsi	<input checked="" type="checkbox"/>	<input checked="" type="checkbox"/>	<input checked="" type="checkbox"/>	2,000,000
PPS71 Quartz	<input checked="" type="checkbox"/>	<input checked="" type="checkbox"/>	350°C	18kpsi	<input checked="" type="checkbox"/>	<input checked="" type="checkbox"/>	<input checked="" type="checkbox"/>	2,000,000
PPS71 G-CCL	<input checked="" type="checkbox"/>	<input checked="" type="checkbox"/>	N/A	N/A	N/A	<input checked="" type="checkbox"/>	<input checked="" type="checkbox"/>	2,000,000



PPS71 PT Geothermal Tools - Memory / SRO

The **PPS71 PT Geothermal Tools** are designed for extreme, high temperature downhole conditions. The robust electronics combined with vacuum flask technology allow these products to perform at 350 °C (662 °F) continuously, for four hours. The tool measures pressure and temperature, and can be configured as either a memory tool or surface read out (SRO) tool. The measurements are done with a highly sensitive silicon-sapphire (piezo) transducer and a resistance temperature detector (RTD). The RTD is exposed to the well fluids for faster response and higher accuracy.



Pressure Measurement

Sensor Type	Silicon-Sapphire
Pressure Range	5K psi 10K psi
Accuracy	± 0.03% FS
Resolution	0.0003% FS

Temperature Measurement

Sensor Type	RTD (Pt1000; 4-wire)
Temperature Range	300 °C (572 °F) 350 °C (662 °F)
Accuracy	± 0.5 °C
Resolution	0.01 °C

Environmental

Temperature Rating—Standard Housing	177 °C (350 °F)
Temperature Rating—Flask Housing	300 °C (572 °F) OD 1.56" 350 °C (662 °F) OD 1.75"
Downhole Time (OD 1.75")	4 hours at 350 °C (662 °F) 6 hours at 300 °C (572 °F) 8 hours at 250 °C (482 °F) 10 hours at 200 °C (392 °F)
Downhole Time (OD 1.56")	4 hours at 300 °C (572 °F) 5.5 hours at 250 °C (482 °F) 7.5 hours at 200 °C (392 °F)

Features:

- Operating temperatures up to 350 °C (662 °F)
- Fast response RTD temperature sensor
- Operates in either memory or surface read out mode
- Surface read out mode using e-line is compatible with the Warrior or PPS SRO acquisition system
- Can be combined with PPS36 DepthWatcher if depth measurement is needed

PPS71 PT Geothermal Tools - Memory / SRO

Memory Tool Specifications

Sampling Rate	0.1 s – 1.8 hrs/per sample
Data Sets	Time / Pressure / Temperature
Memory Capacity	6,000,000 data Sets
Communication Interface	USB
Communication Rate	115,200 bits/s
Operation Voltage	2.7 – 3.9 VDC
Battery	180 °C (356 °F) C-size Li-battery (5 A hr/3.6 V)
Connector	Lemo 6 pin with locker

Surface SRO Interface

Transmitter Sampling Rate	0.1 s – 1.8 hrs/per sample
Data Transmission Rate	9,600 bits per second via standard electrical cable
Data Transmission Distance	Up to 7,000 meters via standard electrical cable
Compatibility	Warrior 8 or newer versions
Communication Port	USB 2.0 to PC
Power Input	100 - 240 VAC
Surface Unit Power Output	+60 VDC
Working Temperature	-40 °C (-40 °F) to 85 °C (185 °F)
Humidity	90%
Condensation	No
Material	Aluminum
Connectors	1 AC Power, 1 DC Power, 1 USB Port and 1 Gauge Interface
Dimensions–inches	7.75 (196 mm) x 4 (101 mm) x 3.25 (82 mm)
Interface	USB 2.0

Mechanical and Materials

Service	Sour Services
Outside Diameter–inches	1.56 (39 mm) Memory Only 1.75 (44 mm)
Overall Length Memory Tool–inches	59.3 (1,506 mm) with bullnose
Overall Length SRO Tool–inches	104.5 (2,654 mm) with bullnose
Housing Material	Stainless Steel 17-4 Inconel 718

PPS71 PT Tool



SRO Transmitter

SRO Adapter



SRO Surface Box



PPS36 DepthWatcher

PPS71 PTS & PTS-C Geothermal Tools

The **PPS71 PTS-C Geothermal Tools** are designed for extreme subsurface conditions. The robust electronics combined with vacuum flask technology allow these products to perform at 350 °C (662 °F) continuously, for four hours. The tool measures pressure, temperature, casing collar location, and flow profile and can be configured as either a memory tool or surface read out tool (SRO) tool. The measurements are done with a highly accurate silicon-sapphire (piezo) transducer, a fast response resistance temperature detector (RTD), the customer's choice of either a continuous or fullbore spinner flowmeter and a highly sensitive CCL. The PPS71 PTS-C's CCL has a magnet and central coil arrangement which amplifies current providing a readable voltage spike or "collar kick" as data, giving end users an important control for depth correlation.



Pressure Measurement

Sensor Type	Silicon-Sapphire
Pressure Range	5K psi 10K psi
Accuracy	± 0.03% FS
Resolution	0.0003% FS

Temperature Measurement

Sensor Type	RTD (Pt1000; 4-wire)
Temperature Range	300 °C (572 °F) 350 °C (662 °F)
Accuracy	± 0.5 °C
Resolution	0.01 °C

Flow Measurement

Sensor Type	Reed switch/magnetic
Flow Rate Range	5 – 7,000 RPM
Accuracy (≥ 20 RPS)	± 0.5 revolution
Accuracy (≤ 20 RPS)	± 0.25 revolution
Resolution (≥ 20 RPS)	0.5 RPS
Resolution (≤ 20 RPS)	0.1 RPS

Environmental

Temperature Rating—Standard Housing	177 °C (350 °F)	
Temperature Rating—Flask Housing	300 °C (572 °F) OD 1.56" 350 °C (662 °F) OD 1.75"	
Downhole Time (OD 1.75")	4 hours at 350 °C (662 °F) 6 hours at 300 °C (572 °F)	
	8 hours at 250 °C (482 °F) 10 hours at 200 °C (392 °F)	
Downhole Time (OD 1.56")	4 hours at 300 °C (572 °F) 5.5 hours at 250 °C (482 °F)	7.5 hours at 200 °C (392 °F)

Features:

- Operating temperatures up to 350 °C (662 °F)
- Fast response RTD temperature sensor
- Continuous or full-bore spinners are available
- Operates in either memory or surface read out mode
- Surface read out mode using e-line is compatible with the Warrior or PPS SRO acquisition system
- Can be combined with PPS36 DepthWatcher if depth measurement is needed

PPS71 PTS & PTS-C Geothermal Tools

Memory Tool Specifications

Sampling Rate	0.1 s – 1.8 hrs/per sample
Data Sets	Time / Pressure / Temperature / Flow
Memory Capacity	6,000,000 data Sets
Communication Interface	USB
Communication Rate	115,200 bits/s
Operation Voltage	2.7 – 3.9 VDC
Battery	180 °C (356 °F) C-size Li-battery (5 A hr/3.6 V)
Connector	Lemo 6 pin with locker

Surface SRO Interface

Transmitter Sampling Rate	0.1 s – 1.8 hrs/per sample
Communication Distance	7,000 meters
Data Transmission Rate	9,600 bits per second via standard electrical cable
Data Transmission Distance	Up to 7,000 meters via standard electrical cable
Compatibility	Warrior 8 or newer versions
Communication Port	USB 2.0 to PC
Power Input	100 - 240 VAC
Surface Unit Power Output	+60 VDC
Working Temperature	-40 °C (-40 °F) to 85 °C (185 °F)
Humidity	90%
Condensation	No
Material	Aluminum
Connectors	1 AC Power, 1 DC Power, 1 USB Port and 1 Gauge Interface
Dimensions–inches	7.75 (196 mm) x 4 (101 mm) x 3.25 (82 mm)
Interface	USB 2.0

Mechanical and Materials

Service	Sour Services
Outside Diameter–inches	1.56 (39 mm) Memory Only 1.75 (44 mm)
Overall Length Memory Tool–inches	66.7 (1,694 mm) 1.75" OD tool with 2.125" OD spinner 66.3 (1,684 mm) 1.75" OD tool with 1.69" OD spinner 66 (1,676 mm) 1.56" OD tool with 1.44" OD spinner
Overall Length SRO Tool–inches	111.9 (2,842 mm) with 2.125" OD spinner 111.5 (2,832 mm) with 1.69" OD spinner
Housing Material	Stainless Steel 17-4 Inconel 718

PPS71 PT Tool



PPS71 Elite & Quartz Geothermal Tools

The **PPS71 Elite Geothermal Tools** are designed for extreme, high temperature downhole conditions. The robust electronics combined with vacuum flask technology allow these products to perform at 350 °C (662 °F) continuously, for four hours. The tool measures pressure, temperature, casing collar location, flow profile and gamma rays, and can be configured as either a memory tool or surface read out tool (SRO) tool. The measurements are done with a highly accurate silicon-sapphire (piezo) transducer, a fast response resistance temperature detector (RTD), either a continuous or fullbore spinner flowmeter, magnetic CCL and sensitive gamma ray crystal which detects incoming gamma rays from the formation.



Pressure Measurement

Sensor Type	Silicon-Sapphire	Quartz
Pressure Range	5K psi 10K psi	5K psi 10K psi 18K psi 25K psi
Accuracy	± 0.03% FS	± 0.02%
Resolution	0.0003% FS	<0.01

Temperature Measurement

Sensor Type	RTD (Pt1000; 4-wire)	RTD (Pt1000; 4-wire)
Temperature Range	300 °C (572 °F) 350 °C (662 °F)	300 °C (572 °F) 350 °C (662 °F)
Accuracy	± 0.5 °C	± 0.5 °C
Resolution	0.01 °C	0.01 °C

Flow Measurement

Sensor Type	Reed switch/magnetic	Reed switch/magnetic
Flow Rate Range	5 – 7,000 RPM	5 – 7,000 RPM
Accuracy (≥ 20 RPS)	± 0.5 revolution	± 0.5 revolution
Accuracy (≤ 20 RPS)	± 0.25 revolution	± 0.25 revolution
Resolution (≥ 20 RPS)	0.5 RPS	0.5 RPS
Resolution (≤ 20 RPS)	0.1 RPS	0.1 RPS

Gamma Measurement

Sensor Type	Crystal, NaI (scintillation type)	Crystal, NaI (scintillation type)
Sensitivity	Typically 1.7 CPS/API	Typically 1.7 CPS/API

PPS71 Elite & Quartz Geothermal Tools

Environmental

Temperature Rating–Standard Housing	177 °C (350 °F) with standard housing	
Temperature Rating–Flask Housing	300 °C (572 °F) OD 1.56" 350 °C (662 °F) OD 1.75"	
Downhole Time (OD 1.75")	4 hours at 350 °C (662 °F) 6 hours at 300 °C (572 °F)	
	8 hours at 250 °C (482 °F) 10 hours at 200 °C (392 °F)	
Downhole Time (OD 1.56")	4 hours at 300 °C (572 °F) 5.5 hours at 250 °C (482 °F)	
	7.5 hours at 200 °C (392 °F)	

Memory Tool Specifications

Sampling Rate	0.1 s – 1.8 hrs/per sample	
Data Sets	Time / Pressure / Temperature / Flow / CCL / Gamma	
Memory Capacity	2,000,000 data Sets	
Communication Interface	USB	
Communication Rate	115,200 bits/s	
Operation Voltage	5.5 – 7.2 VDC	
Battery	165 °C (329 °F) Two C size Li-battery (5 A hr/7.2 V)	
Connector	Lemo 4 pin with locker	

Surface SRO Interface

Data Transmission Rate	9,600 bits per second via standard electrical cable	
Data Transmission Distance	Up to 7,000 meters via standard electrical cable	
Compatibility	Warrior 8 or newer versions	
Communication Port	USB 2.0 to PC	
Power Input	100 - 240 VAC	
Surface Unit Power Output	+60 VDC	
Working Temperature	-40 °C (-40 °F) to 85 °C (185 °F)	
Humidity	90%	
Condensation	No	
Material	Aluminum	
Connectors	1 AC Power, 1 DC Power, 1 USB Port and 1 Gauge Interface	
Dimensions–inches	7.75 (196 mm) x 4 (101 mm) x 3.25 (82 mm)	
Interface	USB 2.0	

Mechanical and Materials

Service	Sour Services	
Outside Diameter–inches	1.56 (39 mm) Memory Only 1.75 (44 mm)	
	1.83 (46 mm) Memory Only 1.85 (47 mm)	
Overall Length	Tool has multiple configurations, please contact a PPS representative for details	
Housing Material	Inconel 718 Monel K500	



SRO Surface Box



PPS36 DepthWatcher



SRO Transmitter

PPS71 Quartz Tool with Flask

PPS71 G-CCL Geothermal Tools

The **PPS71 G-CCL Geothermal Tools** are designed for extreme, high temperature downhole conditions. The robust electronics combined with vacuum flask technology allow these products to perform at 350 °C (662 °F) continuously, for four hours. The tool measures casing collar location, and gamma rays, and can be configured as either a memory tool or surface read out tool (SRO) tool.



PPS71 G-CCL

Pressure Measurement

Sensor Type	Silicon-Sapphire
Pressure Range	5K psi 10K psi
Accuracy	± 0.03% FS
Resolution	0.0003% FS

Temperature Measurement

Sensor Type	RTD (Pt1000; 4-wire)
Temperature Range	300 °C (572 °F) 350 °C (662 °F)
Accuracy	± 0.5 °C
Resolution	0.01 °C

Flow Measurement

Sensor Type	Reed switch/magnetic
Flow Rate Range	5 – 7,000 RPM
Accuracy (≥ 20 RPS)	± 0.5 revolution
Accuracy (≤ 20 RPS)	± 0.25 revolution
Resolution (≥ 20 RPS)	0.5 RPS
Resolution (≤ 20 RPS)	0.1 RPS

Environmental

Temperature Rating—Standard Housing	177 °C (350 °F)	
Temperature Rating—Flask Housing	300 °C (572 °F) OD 1.56" 350 °C (662 °F) OD 1.75"	
Downhole Time (OD 1.75")	4 hours at 350 °C (662 °F) 6 hours at 300 °C (572 °F)	
	8 hours at 250 °C (482 °F) 10 hours at 200 °C (392 °F)	
Downhole Time (OD 1.56")	4 hours at 300 °C (572 °F) 5.5 hours at 250 °C (482 °F)	
	7.5 hours at 200 °C (392 °F)	

Features:

- Operating temperatures up to 350 °C (662 °F)
- Operates in either memory or surface read out mode
- Surface read out mode using e-line is compatible with the Warrior or PPS SRO acquisition system
- Can be combined with PPS36 DepthWatcher if depth measurement is needed

PPS71 G-CCL Geothermal Tools

Memory Tool Specifications

Sampling Rate	0.1 s – 1.8 hrs/per sample
Data Sets	Time / Pressure / Temperature / Flow
Memory Capacity	6,000,000 data Sets
Communication Interface	USB
Communication Rate	115,200 bits/s
Operation Voltage	2.7 – 3.9 VDC
Battery	180 °C (356 °F) C-size Li-battery (5 A hr/3.6 V)
Connector	Lemo 6 pin with locker

Surface SRO Interface

Transmitter Sampling Rate	0.1 s – 1.8 hrs/per sample
Communication Distance	7,000 meters
Data Transmission Rate	9,600 bits per second via standard electrical cable
Data Transmission Distance	Up to 7,000 meters via standard electrical cable
Compatibility	Warrior 8 or newer versions
Communication Port	USB 2.0 to PC
Power Input	100 - 240 VAC
Surface Unit Power Output	+60 VDC
Working Temperature	-40 °C (-40 °F) to 85 °C (185 °F)
Humidity	90%
Condensation	No
Material	Aluminum
Connectors	1 AC Power, 1 DC Power, 1 USB Port and 1 Gauge Interface
Dimensions–inches	7.75 (196 mm) x 4 (101 mm) x 3.25 (82 mm)
Interface	USB 2.0

Mechanical and Materials

Service	Sour Services
Overall Length Memory Tool–inches	76.1 (1,933 mm) 1.75" OD tool
Overall Length SRO Tool–inches	100.6 (2,555 mm) 1.75" OD tool
Housing Material	Inconel 718

Fullbore Spinner

The $\phi 43$ mm six arm caged fullbore flowmeter uses a collapsible spinner to measure the flowrate. When the tool passes through a constriction, the arms close with the spinner stopped and folded for protection. In the larger diameter of casing, the arms open with the spinner unfolded. When fluids flow through the spinner, it rotates at a speed proportional to the speed of fluids flow. The rotation is coupled through the magnets to the magneto sensitive elements in the electronics section and is processed in circuit to get the corresponding pulse signal, so as to get the flowrate of the well fluids.



Pressure

Maximum Pressure–MPa	80 (11.6K psi)
----------------------	----------------

Temperature

Maximum Rating–°C	350 (662°F)
-------------------	-------------

Characteristics

Threshold	0.55-0.76m/min (1.8-2.5ft/min)
Weight	Approximately 1.5 Kg
Size	$\phi 43 \times 526$ mm (11,116 "x20.7")
Zero Length	232 mm (9.13")
Make-up Length	479 mm (18.86")
MAX OD	$\phi 105$ mm (4.13")
Min OD	$\phi 96$ mm (3.78")
Spinner Diameter	$\phi 64$ mm (2.52")

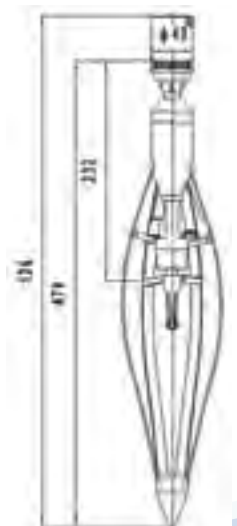

PPS36 DepthWatcher

The **PPS36 DepthWatcher** is a portable depth recorder that runs on batteries or external power and has an LCD display that an operator can use to see the actual depth, speed, and tension during a slickline job. The recorder can be set up using a very simple menu or by connecting to a PC. It can be operated on a stand alone mode (Memory) or on a real time mode (SRO) with the use of a PC to display depth, speed, tension and two additional channels. It is also equipped with three additional 4-20mA channels for measuring other wellhead parameters.



Characteristics

Depth Accuracy	±0.3 ft. (0.1 m)
Display	LCD Graphic Display (320 x 240)
Memory	48 MBytes
Power Input Voltage	6 - 28 VDC, 200 mA at 12 VDC or Lithium Battery Pack
Sampling Rate	0.1 second to 1.8 hours
Encoder	+5 V Optical Encoder (512 pluses per rev. or better)
External Channels	3 x 4 - 20 mA
Depth Alarm	Up to 8 w/Close to Surface Alarm
Speed Alarm	One
Tension Alarm	One
Dimensions–inches	4.30 (H) x 7.90 (W) x 9.10 (L)
Weight	8 lbs
Operating Temperature	-20 °C (-4 °F) to 70 °C (158 °F)
Communication	USB 2.0 (Type–B Port)
Data Transfer Rates	Up to 1.8 Mbits/second
Enclosure Type	NEMA 4

Applications:

- Slickline Depth Recorder
- Coiled Tubing Depth Recorder with Customized Adapter
- Wireline Depth Recorder



Smart Gauges and Simple Software



Pioneer Petrotech Services Inc.

#1, 1431-40 Avenue NE, Calgary, Alberta Canada T2E 8N6

Tel: 1-403-282-7669

Fax: 1-403-282-0509

Toll Free in Canada & USA: 1-888-PP-GAUGE (774-2843)

E-mail: sales@pioneerps.com

www.pioneerps.com

SÜDBAU
ARGENTINA
CENTRO DE SERVICIOS
REGIONAL
www.sudbau.com.ar